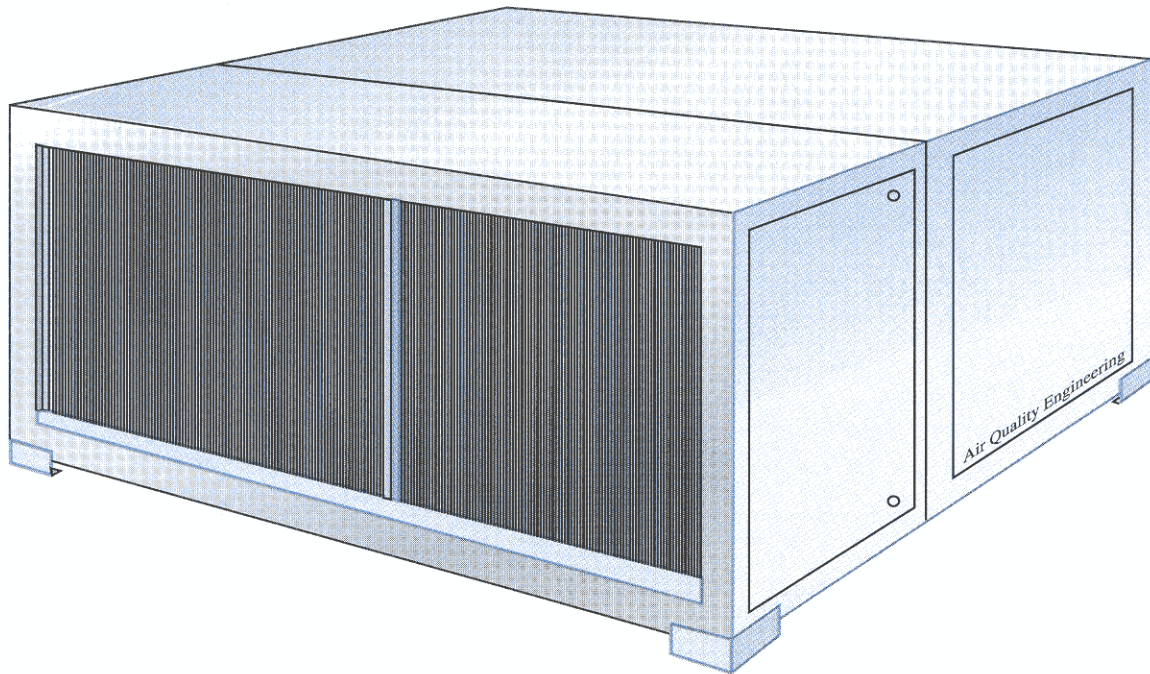

S U P P L Y I N G C L E A N A I R T O I N D U S T R Y

New!

MODEL M73

MicroGlass Air Cleaner

FEATURING THE NEW EXTENDED SERVICE FILTER



The new M73 from Air Quality Engineering, Inc. is a self-contained media air cleaning system designed for general background or ducted for source capture applications. The M73 includes the new E.S.F. MicroGlass Filters for long filter life and high efficiencies to effectively remove smoke, mist, dust and other airborne contaminants at a rate of up to 6000 CFM.

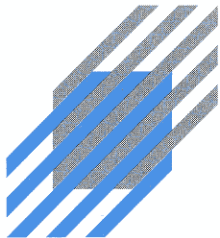

**AIR QUALITY
ENGINEERING**

Manufacturer and Worldwide Distributor of Air Cleaning Systems for Over 25 Years

M73 FEATURES & SPECIFICATIONS

DIMENSIONS: 49.50"L x 46.50"W x 31.60"H

WEIGHT: Installed: 405 lbs.; Shipping: 465 lbs.

CABINET: 16 gauge galvanized steel.

POWER INPUT: 208-240 Vac, 60 Hz, 3Ø, 9 Amps
440-480 Vac, 60 Hz, 3Ø, 5 Amps

PRIMARY FILTER SPECIFICATIONS: Construction: Rigid V-Bank Configuration
Element: Mini-pleated microglass fiber
Number: 2 filters per unit
Dimensions: 23³/₈" x 23³/₄" x 11¹/₂"
Weight: 13.25 lbs. each
Collection Area: 400 sq. ft. with two filters

AIRFLOW/EFFICIENCY:

ASHRAE 52.76	CFM (AMBIENT)
45-50%	6000
60-65%	5200
80-85%	4975
90-95%	4850
DOP 95%	4500

AMBIENT TEMPERATURE: 175°F Maximum

MOUNTING: Standing or hanging cabinet with horizontal airflow. Ceiling mount brackets – standard.

PREFILTER: Two 30-35% efficient pleated filters, 24" x 24" x 4". Filter media is a cotton and synthetic blend. Total prefilter media area is 59 ft.

MOTOR: 3 HP sealed ball bearings and thermally protected. Adjustable sheave allows air flow adjustments of up to 800 CFM.

BLOWER: Belt driven, dual centrifugal blower wheels with ball bearings.

INSTRUMENTATION: **Dirty Filter Gauge** – Factory installed pressure gauge designed to determine filter replacement cycle.

FILTER ACCESS: Side load track system with hinged access door.

ADDITIONAL FEATURES: 3 year parts warranty.
400 sq. ft. of media.
4-way adjustable exhaust louvers.
Motor starter and control circuitry.
Dirty filter gauge.

OPTIONS INCLUDE: Custom source capture plenum.
Impinger/drain pan.
95% DOP efficiency.

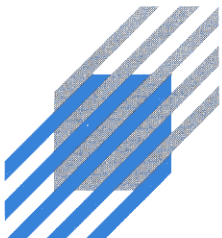
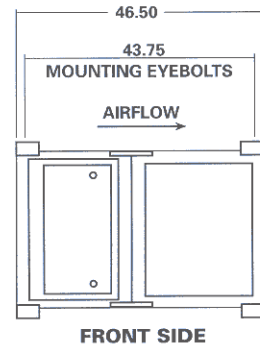
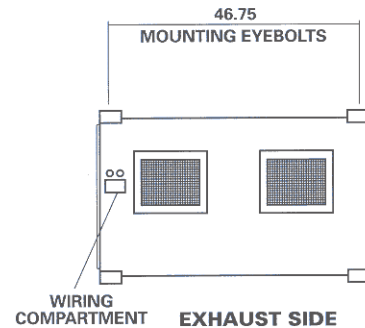
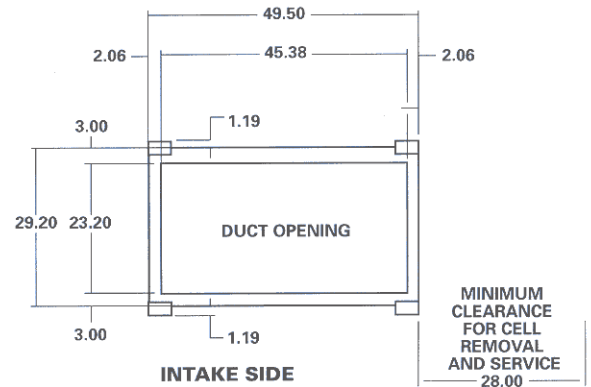
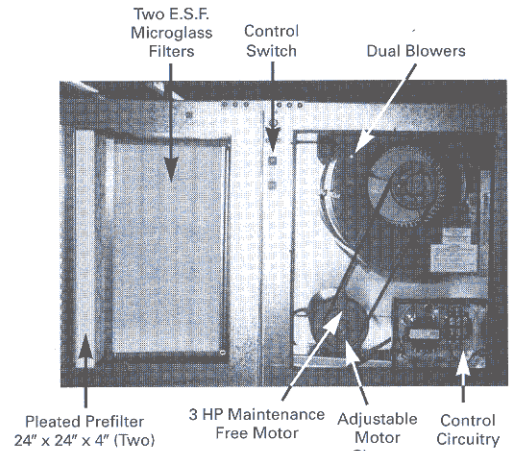

**AIR QUALITY
ENGINEERING**

AIR QUALITY ENGINEERING, INC.

7140 Northland Drive North
Minneapolis, MN 55428-1520
(800) 328-0787 • Fax: (763) 531-9900
aqe@isd.net • www.air-quality-eng.com